

Raleigh Time Recorder Company

2252 Rumson Road Raleigh, NC 27610-1039

919-833-6893 FAX 828-7349 email: ty@raleightime.com

www.raleightime.com

Rapidprint Ribbon Change Procedure

CHANGING RIBBON

To Remove Ribbon (*figure 17*)

UNPLUG MACHINE FROM OUTLET. Unlock the machine and raise the top casting until it is fully open. Turn the machine sideways so that the lock is facing the operator.

Turn one of the ratchet wheels (A) one revolution to create slack in the ribbon. Lifting the ribbon feeler (B) out of the way, place your index finger behind spool flange (C). Applying pressure towards operator, swing ribbon spool away (*figure 17*). Repeat operation for other side. Discard ribbon.

WARNING: NEVER ATTEMPT TO RE-INK RIBBON. THIS WILL CLOG THE WHEELS, CAUSE AN OPERATIONAL FAILURE AND WILL VOID THE GUARANTEE.

Installing New Ribbon (*figure 17*)

Hold onto the ribbon spools so that notched flange (C) faces ratchet wheel (A). Starting with spool closest to front of machine, insert flange (D) onto spring loaded stud. Lifting ribbon feeler, position notched flange (C) into place until spool is trapped between studs. Rotating spool slightly may be necessary. Install remaining ribbon spool by slipping ribbon under feeler (B) and repeating installation procedure. Turn one of the ratchet wheels (A) providing enough tension to flatten ribbon.

“C” side of spool is either notched or has rings on it with a rectangular hole.

“D” side of spool is smooth with a round hole.

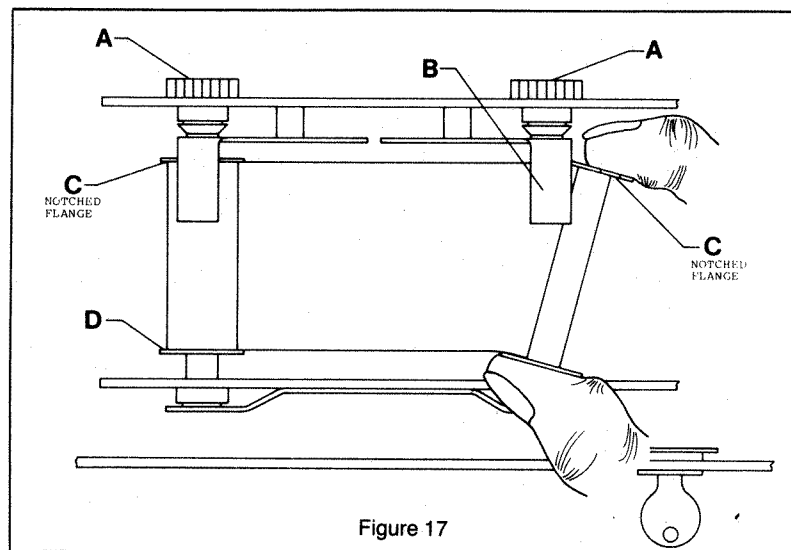

Figure 17